

**Takeuchi**<sup>TM</sup>  
From World First to World Leader

**HYDRAULIC EXCAVATOR**

# TB3150

PROUDLY DISTRIBUTED BY



**MATERIAL HANDLING**

**1800 425 438**

[toyotatakeuchi.com.au](http://toyotatakeuchi.com.au)



**Operating Weight: 15,765 kg**

# TOUGH, POWERFUL, RELIABLE

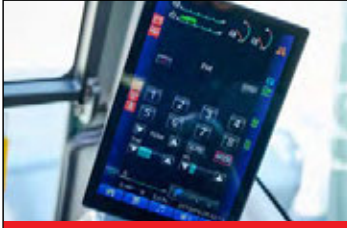

8" Touch Screen Display



Intuitive Operation



Multi Functional Grips (OPT)



Takeuchi Access Management

Building upon the renowned strengths and proven performance of its predecessor, the TB2150, the new TB3150 delivers a powerful evolution, engineered for demanding applications. It retains the qualities the market values while significantly elevating operational efficiency, performance, and comfort. Its boom swing system is unique in the 15-ton class and provides the TB3150 with greater functionality, offering a huge advantage over the competition.

The TB3150 boasts significantly increased hydraulic horsepower. This crucial upgrade boosts performance in simultaneous operations, particularly those requiring high pressure.

Advancements in design and operator well-being are clear throughout the TB3150. Its interior and exterior designs from our 3 Series have been seamlessly integrated, creating a refined, comfortable, and highly functional operating environment. To maximize operator comfort and control, the TB3150 features a large 8-inch color touch screen display, optional multifunctional grips for tailored operation, sophisticated integrated electronic control for specific operations, improved cab visibility, and height-adjustable handrails for transport flexibility.

Finally, the TB3150 sets a new standard for security with the Takeuchi Access Management System. This groundbreaking keyless start feature assigns a unique user ID to each machine. Operators can start a machine using a registered passcode or an optional RFID key, ensuring only authorized personnel can operate it, thus providing invaluable peace of mind and robust protection.



Completely Redesigned Automotive Styled Interior with Intuitive Operation

# Product Features

## ENGINE

- EU Stage V / EPA Tier 4 Emission Compliant
- DOC+DPF+SCR Exhaust After Treatment
- Automatic Fuel Bleed System
- Double Element, Air Cleaner
- Automatic Deceleration
- Working Modes: Standard and ECO
- Bi-metal Clutch Fan Engagement for Radiator
- Fuel Supply Pump w/ Reel System
- Engine Safety Start System on the Left Console
- Engine Auto Stop

## ELECTRICAL

- 8" Color Touch Screen Display
- 270 Degree Camera
- Multi-Switch Control Panel & Jog Dial Control
- EH Controls for Travel, Dozer Blade and Boom Swing
- Travel Alarm
- LED Light Package
- TFM (Takeuchi Fleet Management; GPS)\*
- Takeuchi Access Management System (Engine Push Start)
- LED Additional Boom Light

## OPERATOR'S STATION

- Cab with Auto Air Conditioner, Windshield Wiper and Washer, Skylight with Sunshade, Rain Guard, DAB Radio with Bluetooth Hands-Free Function and USB Port (TYPE-C)
- ROPS / OPG(Top Guard, Level II)
- Hands-Free Microphone
- Air Suspension Seat with Heat
- 2" Retractable Seat Belt
- OPG Level II Front Guard

## UNDERCARRIAGE AND FRAME

- Triple Flanged Track Rollers
- 2-Speed Travel with Automatic Shift
- 500 mm Rubber Crawlers
- Heavy Counterweight
- Heavy Duty Dozer Blade with Float
- Rubber Pads for 500 mm Steel Crawlers

## TAKEUCHI FLEET MANAGEMENT

- Minimize Downtime
- Remote Diagnostics
- Utilization Tracking
- Proactive Maintenance
- Control Costs

## HYDRAULIC

- Variable Displacement, Open Center Hydraulics
- Hydraulic Joystick Controls
- Proportional Control for 1st Auxiliary Hydraulic Line
- Proportional Control for 2nd Auxiliary Hydraulic Line
- 3rd Auxiliary Hydraulic Control for Quick Hitch
- Adjustable Auxiliary Flow for 1st, 2nd and 4th Auxiliary Hydraulic Lines
- Pilot Accumulator
- Proportional Control for 4th Auxiliary Hydraulic Line (optional)
- Proportional Control for 4th Auxiliary Hydraulic Line (Independent) with Multi-Functional Grips (optional)
- Auxiliary Hydraulic Line Performance Package ; Auto Tank for 1st AUX, Auto Pressure Release for 1st & 2nd AUX and Pressure Adjustment for 1st & 2nd AUX

## WORKING EQUIPMENT

- Boom Swing System
- 2,570 mm Arm
- Arm and Boom Holding Valve with Lift Alarm
- Pattern Change Valve (ISO or G)



Easy Service Access with Wide-Opening Covers



Convenient Service and Maintenance Access

\* Functions may not be available in all countries, so please consult your Takeuchi dealer for details.

# Product Specifications

## OPERATING PERFORMANCE Mono Boom

Operating Weight (Steel Crawlers)	15,895 kg
Bucket Capacity (Heaped)	0.45 m <sup>3</sup>
Slew Speed	11.0 min <sup>-1</sup>
Travel Speed	
1st	3.1 km/h
2nd	5.5 km/h
Gradeability	35°
Ground Pressure	
Steel Crawlers	50.0 kPa
Maximum Bucket Breakout Force	96.3 kN
Maximum Arm Digging Force (2,570 mm Arm)	55.8 kN
Traction Force	157.5 kN
Boom Swing Angle (Left/Right)	77° / 53°

## ENGINE

Model	Yanmar 4TN101FHT-2STB
Rated Output (ISO 14396)	85 kW/2200 min <sup>-1</sup>
Maximum Torque	462.8 Nm/1500 min <sup>-1</sup>
Displacement	3,847 ml
Alternator	24 V-1.92 kW
Battery (IEC 60095-1)	12 V - 90 A·h x 2

## FLUID CAPACITIES

Engine Lubrication	14.3 L
Cooling System	18.0 L
Fuel Tank Capacity	273.5 L
Hydraulic Reservoir Capacity	102.3 L
Hydraulic System Capacity	225.0 L
DEF Tank Capacity	20.0 L

## SAFETY and HEALTH

Vibration Levels	
Hand / Arm	≤ 2.5 m/s <sup>2</sup>
Body	≤ 0.5 m/s <sup>2</sup>
Noise Level	
Sound Power Level	LwA 98 dB

## HYDRAULIC SYSTEM

P1, P2	Variable Displacement Pump
Flow Rate	112.0 L/min
Relief Pressure	34.3 MPa
P3	Gear Pump
Flow Rate	22.0 L/min
Relief Pressure	3.9 MPa
P4	Gear Pump
Flow Rate	55.7 L/min
Relief Pressure	23.6 MPa
1st AUX	
Flow Rate	112 L/min
Flow Rate - High Flow	224 L/min
Hydraulic Pressure	27.5 MPa
2nd AUX	
Flow Rate	55.7 L/min
Hydraulic Pressure	23.6 MPa
3rd AUX	
Hydraulic Pressure	21.0 MPa
4th AUX	
Flow Rate	55.7 L/min
Hydraulic Pressure	23.6 MPa



**Boom Swing System**



**TFM**



**270 Degree Camera**



**Tiltable Roof Guard**

# TB3150 Machine/Operating Dimensions

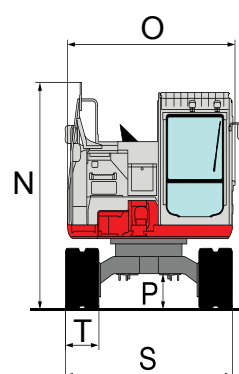
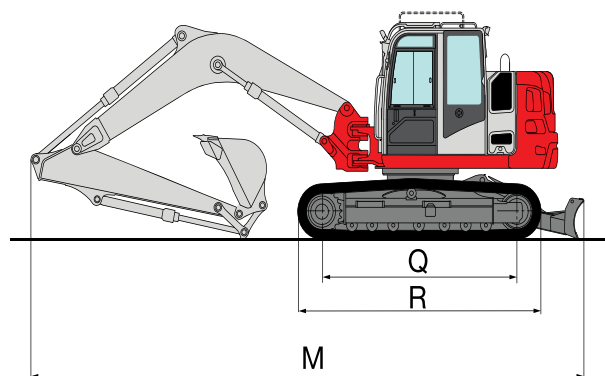
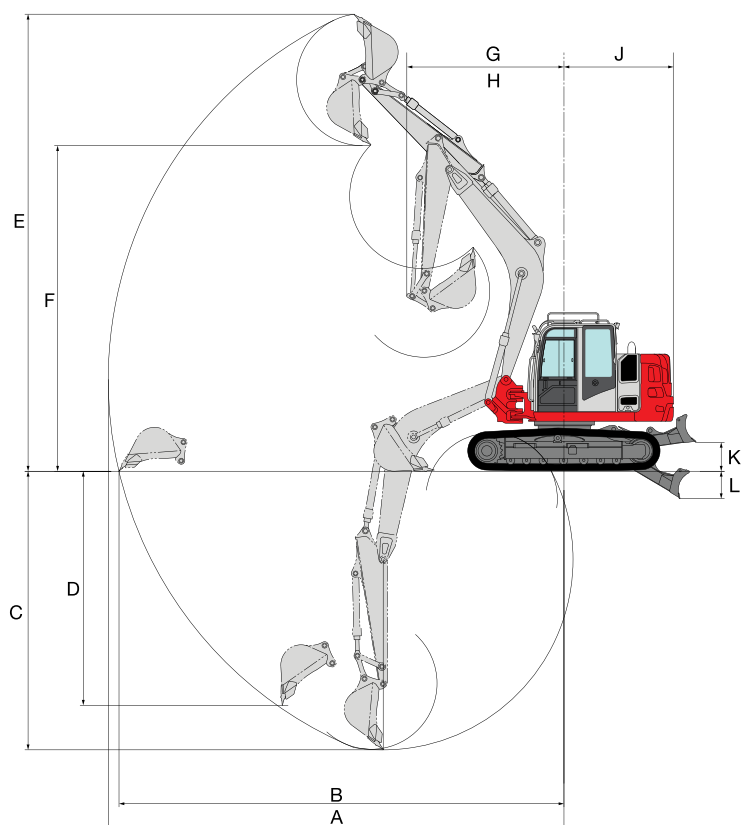

## MACHINE DIMENSIONS

## Mono Boom 2,570 mm Arm

A	Maximum Reach	8,760 mm
B	Maximum Reach at Ground Level	8,565 mm
C	Maximum Digging Depth	5,445 mm
D	Maximum Vertical Digging Depth	4,605 mm
E	Maximum Height of Cutting Edge	8,700 mm
F	Maximum Dumping Height	6,250 mm
G	Front Swing Radius	3,015 mm
H	Front Swing Radius with Boom Offset	2,405 mm
J	Slew Radius	2,050 mm
K	Dozer Blade Maximum Lifting Height	540 mm
L	Dozer Blade Maximum Lowering Height	515 mm
M	Overall Length	8,220 mm
N	Overall Height	2,955 mm
O	Upper Structure Overall Width	2,495 mm
P	Ground Clearance	475 mm
Q	Crawler Base	2,895 mm
R	Crawler Overall Length	3,615 mm
S	Crawler Overall Width	2,490 mm
T	Crawler Shoe Width	500 mm



© 2026 Takeuchi MFG. Co., Ltd. All Rights Reserved. In accordance with our established policy of continued improvement, specifications and features are subject to change without notice. Pictures may show options other than standard equipment.

FORM: TB3150 Excavator Spec Sheet - Apr. 2026

PROUDLY DISTRIBUTED BY



**MATERIAL HANDLING**

**1800 425 438**

[toyotatakeuchi.com.au](http://toyotatakeuchi.com.au)